



Motion Solutions for Packaging Applications

THOMSONTM
Linear Motion. Optimized.

How to Build a Better Packaging Machine

Often the ideal design solution is not about finding the fastest, sturdiest, most accurate or even the least expensive option. Rather, the ideal solution is the optimal balance of performance, life and cost. Thomson is best positioned to help packaging industry machine builders quickly configure the optimal linear motion solution for each application.

The right technology for each job

Frequently the same machine function can be achieved in different ways. Thomson owns the broadest offering of mechanical motion technologies in the industry. We offer unbiased counsel on the optimal choice for each application.

The optimal form, fit and function

Thomson offers the broadest collection of standard products. Modified versions of standard products are routine. White paper solutions are available across the entire portfolio.

Unmatched application expertise

Choose Thomson and gain access to over 70 years of global application and problem-solving experience across many industries.

More competitive packaging machines

Thomson is available early in the design process to help optimize machine performance, life and cost. Then enjoy peace of mind during the production life of your machine as we provide the quality components, predictable costs and on-time delivery to keep your business running smoothly. Thomson is the name you can trust for power transmission and linear motion technologies. Call us today to discuss your next application or any of our 2000+ distribution partners around the world for fast delivery of replacement parts.



Pick-and-Place / Palletizing

Illustrated here are just a few of the many ways that Thomson adds value to packaging machines. For example, this 4-axis pick-and-place robot could be used for palletizing and loading. Thomson linear components and pre-assembled linear systems can be configured into small and large multi-axis motion solutions.

On the vertical axis, a Thomson rolled ball screw driven linear system with Thomson RoundRail linear guides is matched with our Micron gearbox and Deltran power-off brake.

A Thomson profile rail linear guide carries the load and adds stiffness to the horizontal axis with an end-supported ball screw drive.

Micron True Planetary Gearheads are coupled with Kollmorgen servo motors on 3 axes here and in the following applications. A Kollmorgen direct drive rotary servo motor powers the base.

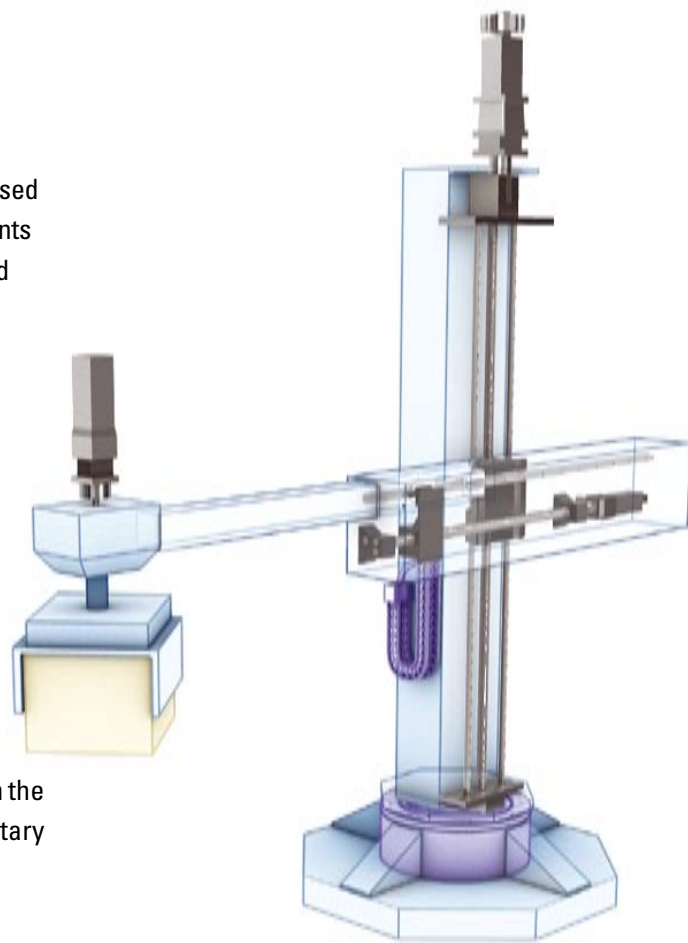

Label Printing / Scanning

Accuracy, high speed and flexibility can be achieved with modest mechanical engineering effort when Thomson is your partner. Our vast breadth of standard motion control components and decades of application experience make your job easy.

In this example, a three axis gantry robot is assembled from a combination of 4 Thomson pre-assembled linear systems with linear guide and ball screw components along a conveyor belt transporting boxes of varying size. A vision recognition system identifies the boxes so that printing (or scanning) can be done while they remain in motion.

Simple engineering achieves optimal performance with Thomson.

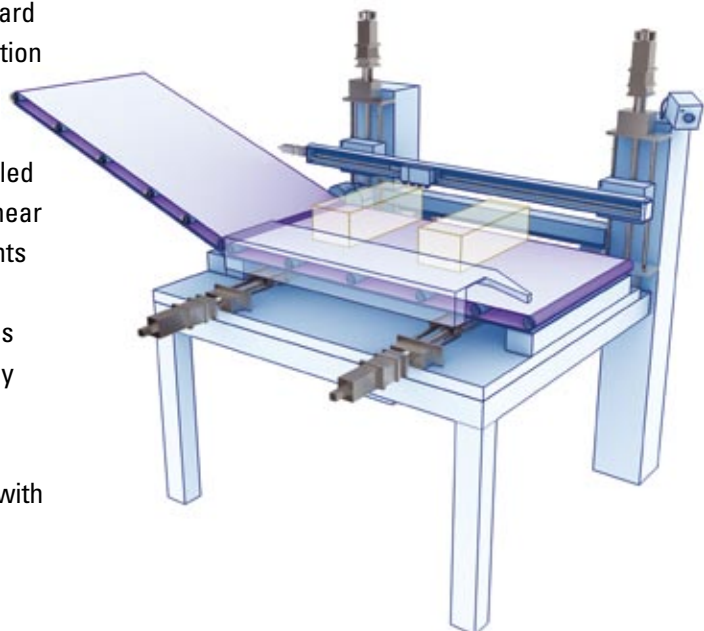

Stretch Wrapping

Simple, high quality machines can be built from standard components providing long life, virtually maintenance free. Unmatched quality, low maintenance and scalable cost are illustrated in single axis motion systems like this stretch wrapping application. Thomson owns multiple linear motion technologies capable of accomplishing the same task and unbiased support to help dial in the optimal balance of performance, life and total cost.

Speed up the design process and fine tune your machine with help from Thomson.

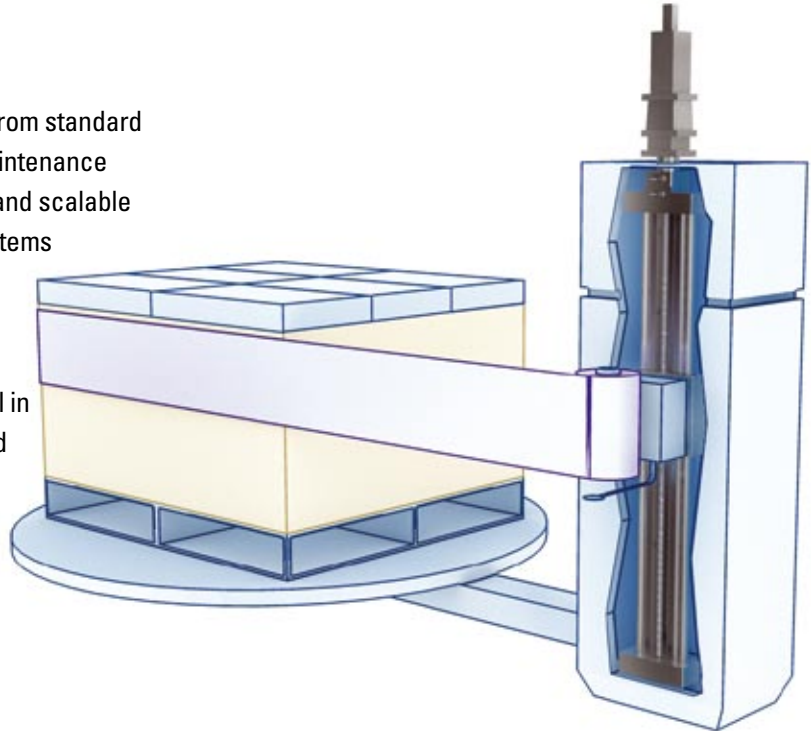

Carton Packing

Building your own production line or manufacturing machines for resale, Thomson is uniquely positioned to help get the job done right the first time.

Carton packing applications, for example, may have special needs best met with a combination of standard and customized mechanical components. At Thomson, modified versions of standard product are routine. White sheet design solutions are available across the entire product portfolio.

In this example, the most efficient and cost effective solution involves a thoughtful combination of pre-assembled Thomson linear systems, separate

linear guide and ball screw components, Deltran clutches and brakes, Micron gearheads and a slightly modified electric linear actuator.

The optimum form, fit and function for your machine is not to be found at competitors with limited product lines and bargain basement parts.

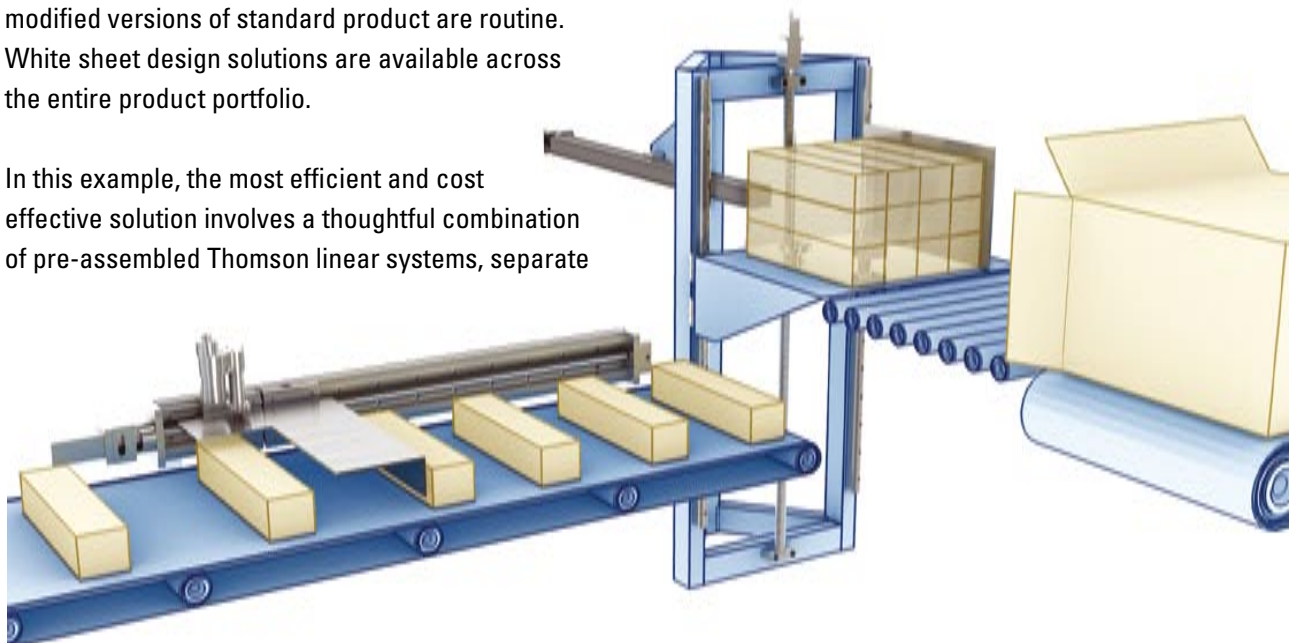

PET Bottle Manufacturing

Choose Thomson as a partner and work side by side with the inventor and longtime owner of multiple mechanical motion technologies. Leverage decades of application experience on six continents to help build your next machine.

Here we illustrate how a Thomson rodless electric actuator can make the more commonly used hydraulic cylinder obsolete, providing better control, higher speed, simpler design, less energy consumption and a more environmentally friendly solution.

Two carriages are mechanically synchronized to optimize pick and place work flow while the rodless electric actuator performs the molding.

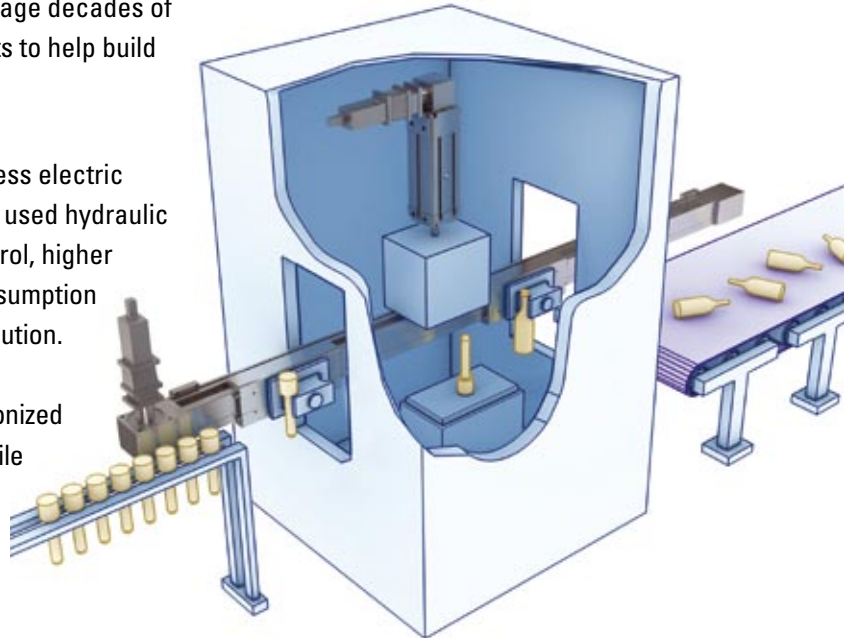

Give Thomson a call to discuss the full range of options to optimize performance and control costs.

Filling

The right mix of linear motion components enables this filling machine the flexibility to handle a wide range of tasks with minimal changeover. A two axis gantry robot moves a tool with nozzles that fill each row of the pallet. Fully enclosed linear systems keep contaminants out of the mechanisms and also eliminate risk of contaminating the filling process.

Work with Thomson early in the design process then enjoy peace of mind during the production life of your machine as we provide the quality components, predictable costs and on-time delivery to keep your business running smoothly.

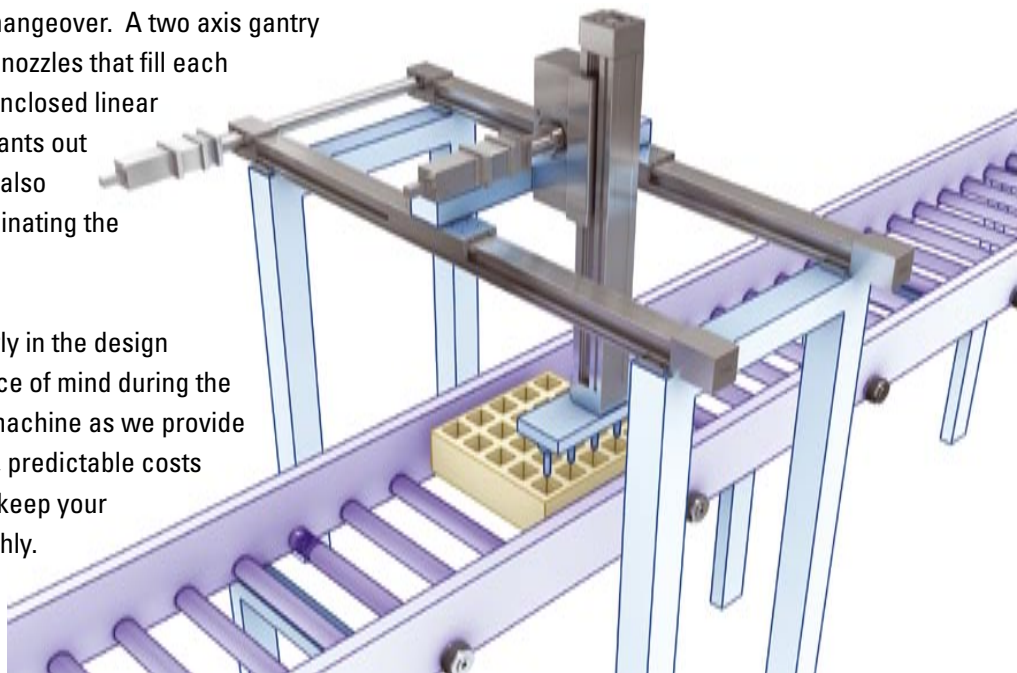

Broadest Line of Rotary and Linear Motion Components

Thomson invented anti-friction linear technology over 70 years ago and has continued to lead the industry ever since. The Thomson brand is recognized and trusted as the global leader in linear motion technology. Thomson understands the critical packaging industry concerns and has developed quality products and solutions to address them.



Profile Rail

With sizes ranging from our ultra compact 5mm MicroGuide™ to the robust 55mm 500 Series roller, as well as compliancy ranging from our self-aligning T-Series (transport profile rail) to the extremely rigid, machine tool grade roller profile rail, Thomson is your “one-stop” source for all your profile rail.



RoundRail Linear Guides & Components

While shafts may appear the same, there are significant performance differences due to the manufacturer’s selected standards and the manufacturing processes used to achieve them. Combine Thomson’s unique design advantages with our tremendous on hand stock, you will have the tools to deliver the difference.



Lead and Ball Screws

Thomson lead screws are the “just right” solution for many linear positioning applications and the patented zero-backlash nut technology provides excellent repeatability with high stiffness and extremely low drag torque. For the more demanding applications we offer the most complete line of industrial ball screws in the industry. Our broad product offering combined with years of application expertise allows us to provide the right solution to meet your unique application requirements.



Linear Actuators

Our linear actuators are designed for rugged, reliable linear motion applications. Numerous choices in stroke, load, motor type, feedback, limits, and control options make these linear actuators very versatile. Talk to us about the many advantages of using electric linear actuators in place of hydraulics or pneumatics. And if you can’t find the actuator to meet your application needs, call us for an actuator built to your needs. We build more custom actuators than anyone in the world.

Optimized Life, Performance and Cost Balance

Thomson is linear motion, optimized. We own the broadest standard product offering of mechanical motion technologies in the industry. Modified versions of standard product are routine. White sheet design solutions are available across our entire product portfolio. Choose Thomson and gain access to over 70 years of global application experience in diverse industries including packaging, factory automation, material handling, medical, clean energy, printing, automotive, machine tool, aerospace and defense.



Clutches and Brakes

Our brake and clutch products are working in a wide range of applications specific to the food and beverage packaging industries. These products set the solid foundation for the broad range of standard and custom products currently available to our customers.

Gearheads

Planetary gearheads are used on high precision motion control applications which require a high torque to volume ratio, high torsional stiffness, and low backlash. Thomson offers these precision planetary gearheads for all duty cycles, and all with RediMount compliant mounting systems. Web-based sizing, selection, pricing and 3D models of Micron gearheads are available at www.micronmotionengineering.com.



Precision Linear Actuators

The compact design and higher load capacities of our precision linear actuators make them ideal for flexible integration in tight areas. These programmable precision linear actuators are available in a wide range of voltage, thrust, stroke and mounting configurations. Designed for high speed, high load, continuous operation. Stroke up to 2m (6.5 ft), load up to 40 kN (9,000 lb) and speed up to 2 m/s (6.5 ft/s).



Linear Motion Systems

Our linear motion systems can be used virtually anywhere. They can support and move a range of loads and provide high precision and tight tolerances. Pre-engineered, pre-assembled, ready to install. The load being supported with either ball guides, slide guides or wheel guides. Actuation with either ball screw, lead screw or belt drive. Support 2D or 3D move profiles with multi-axis configurations. Web-based sizing, selection, pricing and 3D models of Thomson linear systems are available at www.linearmotionengineering.com.

USA, CANADA and MEXICO

Thomson
203A West Rock Road
Radford, VA 24141 USA
Phone: 1-540-633-3549
Fax: 1-540-633-0294
E-mail: thomson@thomsonlinear.com
Literature: www.literature.thomsonlinear.com

EUROPE

United Kingdom

Thomson
Fishleigh Road
Barnstaple
EX31 3UD
United Kingdom
Phone: +44 (0)1271 334 500
Fax: +44 (0)1271 334501
E-mail: sales.uk@thomsonlinear.com

Germany

Thomson
Nürtinger Straße 70
72649 Wolfschlugen
Phone: +49 (0) 7022 504 100
Fax: +49 (0) 7022 504 405
E-Mail: sales.wolfschlugen@thomsonlinear.com

Italy

Thomson
Largo Brughetti
I-20030 Bovisio Masciago
Italy
Phone: +39 0362 594260
Fax: +39 0362 594263
E-mail: info@thomsonlinear.it

Sweden

Thomson
Box 9053
SE-291 09 Kristianstad
Sweden
Phone: +46 (0) 44-24 67 00
Fax: +46 (0) 44-24 40 85
E-mail: helpdesk.kid@thomsonlinear.com

Switzerland

Thomson
La Pierreire 2
1029 Villars-Ste-Croix
Switzerland
Phone: +41 (0) 21 631 33 33
Fax: +41 (0) 21 636 05 09
E-mail: info@thomsonlinear.ch

France

Thomson
C.P 80018
12, Rue Antoine Becquerel – Z.I. Sud
F-72026 Le Mans Cedex 2
France
Phone: +33 (0) 243 50 03 30
Fax: +33 (0) 243 50 03 39
E-mail: sales.france@thomsonlinear

ASIA

China

Thomson
Rm 2205, Scitech Tower
22 Jianguomen Wai Street
Beijing, China, 100004
Phone: +86 10 6515 0260
Fax: +86 10 6515 0263
E-mail: chinainfo@thomsonlinear.com.cn

Japan

Thomson
2F, Sigma Hatchobori Bldg,
2-7-1 Hatchobori Chuo-ku,
Tokyo 104-0032 Japan
Phone: +81-3-6222-1051
Fax: +81-3-6222-1055
E-mail: info@danahermotion.co.jp

Asia Pacific

Thomson
Unit A, 16 Floor, 169 Electric Road
Manulife Tower, North Point
Hong Kong
Phone: +852 2503 6581
Fax: +852 2571 8585
E-mail: victor.lim@thomsonlinear.com

200905-01 TPS ?K TJ 5/2009 USA
Specifications are subject to change without notice. It is the responsibility of the product user to determine
the suitability of this product for a specific application. All trademarks property of their respective owners.
© Thomson Industries, Inc. 2009