

CD Series 5 Drive with AKM Motor Resolver based system

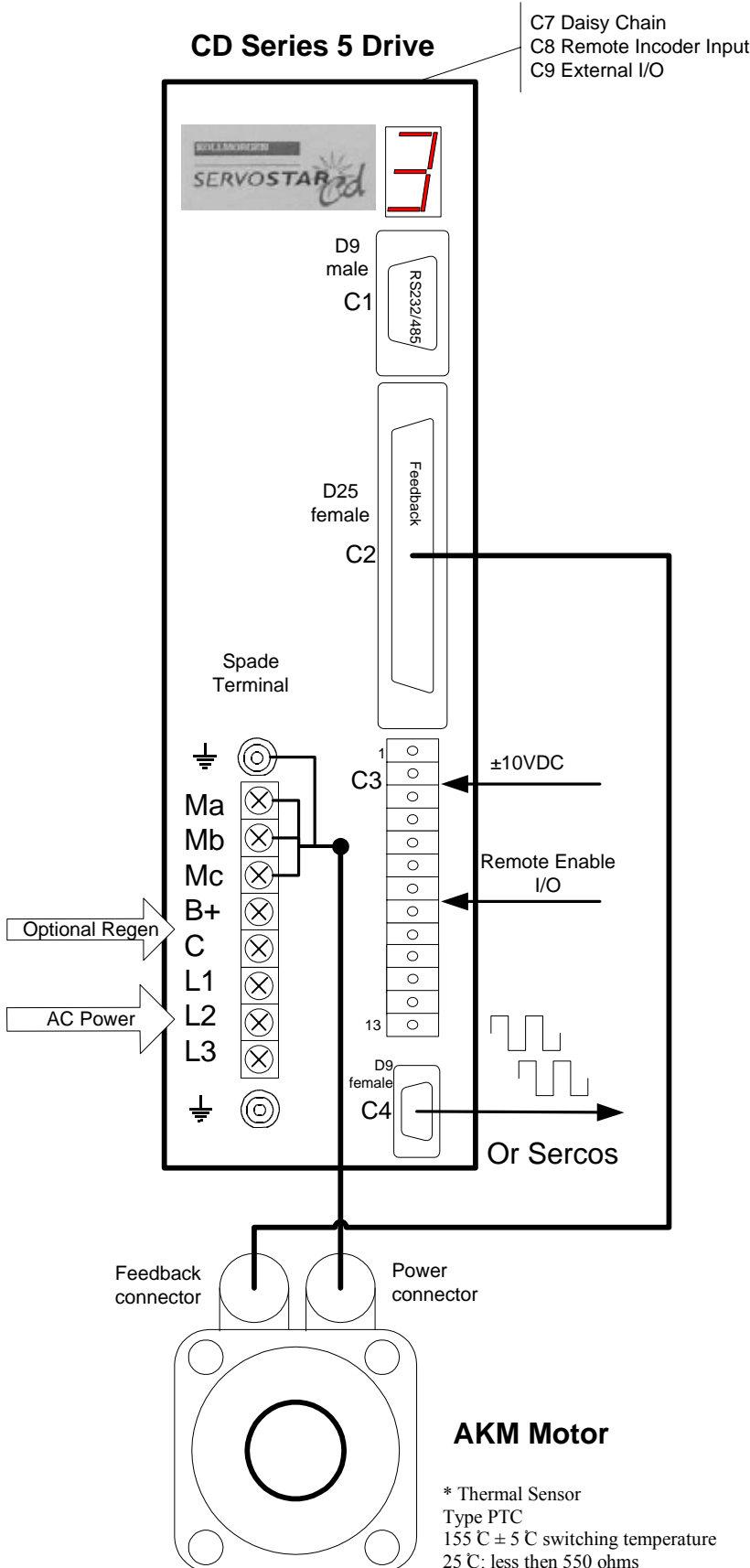

Feedback cable

Drive Feedback C2		Motor Resolver feedback connector	
1	Sine High	3	COS- blue
2	Sine Low	7	COS+ yellow
3	Shield		
4	Cosine High	8	SIN+ red
5	Cosine Low	4	SIN - black
6	Shield		
7			
8			
9			
10			
11			
12	Shield		
13	Thermostat High	2	*Thermal Sensor
14	Shield		
15	Ref High Out	5	Ref - blk/wht
16	Ref Low Out	9	Ref + red/wht
17	Shield		
18			
19			
20			
21	Shield		
22			
23			
24			
25	Thermostat Low	6	*Thermal Sensor

Power cable

Drive Power		Motor Power connector	
GND	Ground	2	PE grn/yel
Ma	Phase A **Bluw	3	W violet
Mb	Phase B **White	4	V brown
Mc	Phase C **Black	1	U blue
		A	Brake +
		B	Brake -

** Colors of standard KM cable

"M" Connector option

Feedback cable

Drive Feedback C2		Motor Resolver feedback connector	
1	Sine High	3	COS- blue
2	Sine Low	7	COS+ yellow
3	Shield		
4	Cosine High	8	SIN+ red
5	Cosine Low	4	SIN - black
6	Shield		
7			
8			
9			
10			
11			
12	Shield		
13	Thermostat High	2	*Thermal Sensor
14	Shield		
15	Ref High Out	5	Ref - blk/wht
16	Ref Low Out	9	Ref + red/wht
17	Shield		
18			
19			
20			
21	Shield		
22			
23			
24			
25	Thermostat Low	6	*Thermal Sensor

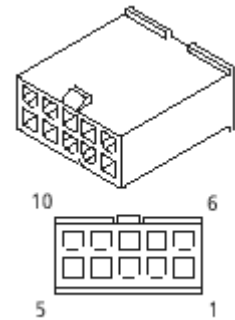

Power cable

Drive Power		Motor Power connector		
GND	Ground	5	Shield	yellow/green
Ma	Phase A	3	W	violet
Mb	Phase B	2	V	brown
Mc	Phase C	1	U	blue
		A	Brake +	
		B	Brake -	

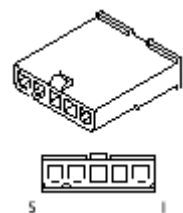

Resolver Requirement and specification

Can use single(two poles) or multi-speed(multiple poles) resolver feedback to monitor the motor shaft

Type: Control transmitter

Transformation Ratio: approx.0.5±0.1

Modulation Frequency: approx. 8 kHz

Input voltage (from drive): 6.36 Vac rms (18Vpp @ 0)

Max DC Resistance: 120 ohm

Max Drive Current: 200mA ac rms

Output voltage: =Input Voltage * Transformation Ratio, 3 Vac

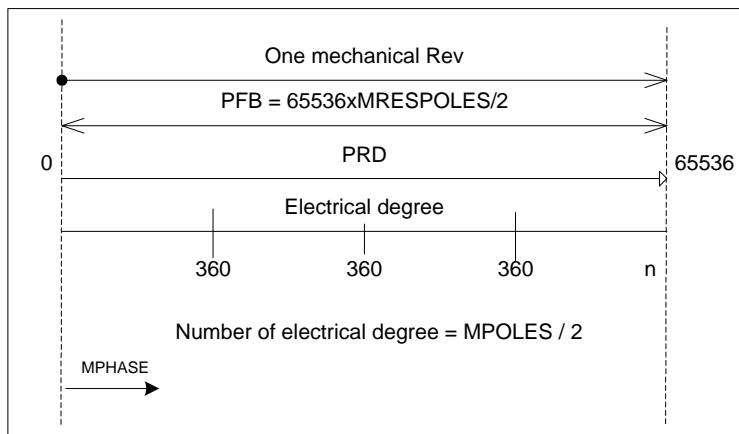
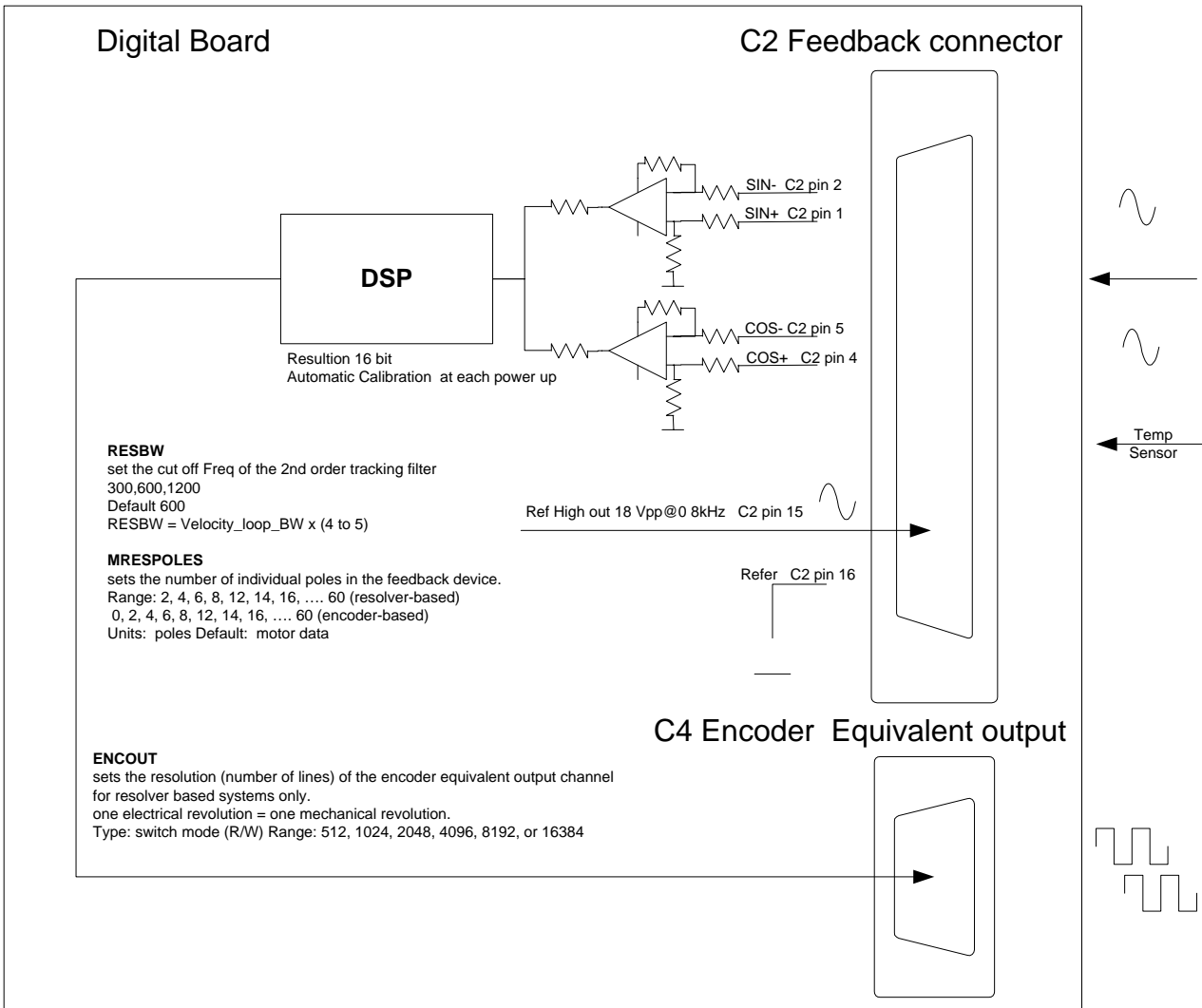

Nomenclature

Historically Kollmorgen motor phases have been designated with the letters 'A', 'B', and 'C' for each of the 3 phase connections. The new AKM motors are labeled 'U', 'V', and 'W'. The relationship of these signals is shown in the following table:

CD Nomenclature	AKM Nomenclature
Phase A	Phase W
Phase B	Phase V
Phase C	Phase U

This translation is important to both the motor lead connections and hall sensor connections as they relate to the commutating encoder versions of the AKM motor series.

Compatible Firmware and Motion Link Revisions

CD Series 5 firmware version 7.0.3, or later, should be installed in the drive. Motion Link version 4.5.0 or later should be installed on the computer. Resolver-based CD Drives with label "Version "TYPE B" are recommended for resolver-based (CRxx5xx) applications. A file named AKM.MO3 must be present in the Motion Link directory

Resolver-Based systems settings and offsets

The resolver alignment position is different in the AKM motors than historically found in Kollmorgen XT or Goldline motors. Setting MOTORTYPE to 3 automatically compensates for this difference.

If MOTORTYPE is set to 0 then the following recommendations must be followed when using a CRxx5xx drive with the AKM motor:

The CD variable called 'MPHASE' must be set to accommodate this difference. The correct value for MPHASE can be calculated using the following formula:

$$\text{MPHASE} = 300 - 90 * (\text{Number of Pole-Pairs})$$

The number of pole pairs for the AKM motor is found on its data sheet. Should the resulting calculation be less than 0 (a negative result) keep adding 360 to the result until the answer is positive. Cutting to the bottom line - MPHASE is 30 for 3 pole pair motors, 300 for 4 pole pair motors, 210 for 5 pole pair motors, and 120 for 6 pole pair motors.

Setting MOTORTYPE to 3 automatically compensate the MPHASE to 0.