

# ACTUATOR CONTROLS

[www.DanaherMotion.com](http://www.DanaherMotion.com)



**THOMSON**<sup>TM</sup>

Solutions by  
**DANAHER**  
MOTION

# Presentation of DCG Actuator Controls

The new DCG actuator controls range is a modern and compact design which is configured for “plug and play” use with specific actuator models from our factory. The DCG range has two basic models. One will control single actuators, the second will synchronously control two parallel actuators.

Both DCG models are supplied with either a built-in electronic limit switch or an electronic collision detection function.



## Electronic limit switches

Controls that have electronic limit switches (ELS) have a built-in function that sense the current draw of the motor. When exceeding a factory set level the actuator stops moving in the direction in question while movement in the opposite direction remains possible. The electronic limit switches can be used to detect the ends of stroke of the actuator as well as detecting obstacles along the movement. However, do not use electronic limit switches as a safety function to avoid personal injuries as the power of the actuator can be very high before the motor is being de-energized.

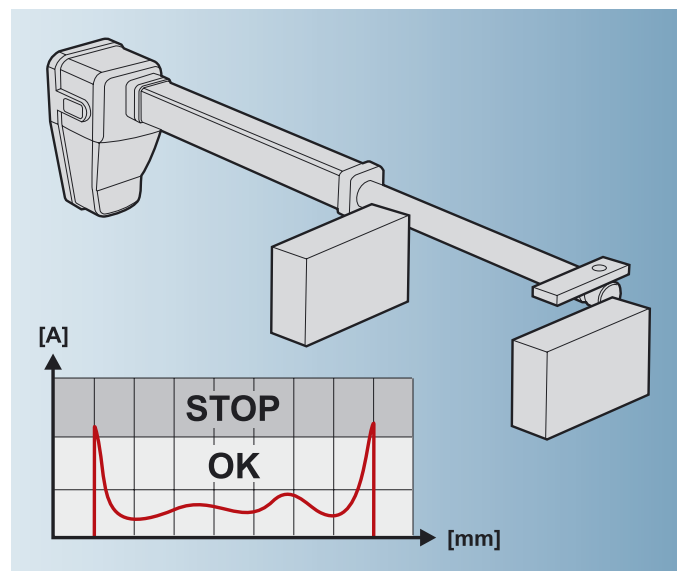

## Parallel synchronous operation

Some versions of the DCG actuator control series can operate two actuators in parallel synchronous motion. To be able to use this feature the actuators must be equipped with feedback encoders. This function is useful when it is necessary to move two actuators to the same position with the same speed at the same time. The loads on the actuators do not need to be the same. The controls for parallel synchronous operation are equipped with an electronic collision detection function which stops both actuators if any of them is stopped or lagging behind due to an obstacle or over load.

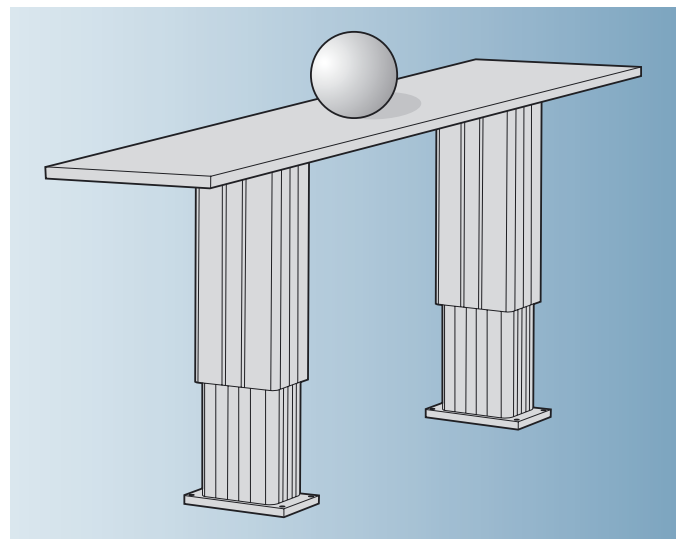

# Technical Data and Ordering Key for DCG Actuator Controls

## Performance Specifications

Parameter		DCG
Supply voltage	[Vac]	230 (115) ± 6 % 50 Hz
Output voltage	[Vdc]	24
Output current, max.	[A]	
DCG24-1 • -0150		4
DCG24-1 • -0160		8
DCG24-1 • -0170		8
DCG24-1 • -0180		8
DCG24-1 • -0190		13
DCG24-2 • -0260		2 × 8
DCG24-2 • -0280		2 × 8
Standby power consumption	[W]	1,1
Life expectancy @ 10 % duty cycle	[h]	20 000
Weight of control	[kg]	1,9
Power supply cable length	[m]	3
Operating temperature limits	[°C]	5 – 45
Max. duty cycle @ 25 °C	[%]	10
Max. on time @ 25 °C	[s]	60
Operating humidity (non-condensing)	[%]	5 – 85
Insulation class		double insulation
Suitable hand control <sup>1</sup>		DCG14-1H
Weight of hand control	[kg]	0,4
Hand control cable length	[m]	1,5

<sup>1</sup> The hand control is ordered separately.

## Dimensions

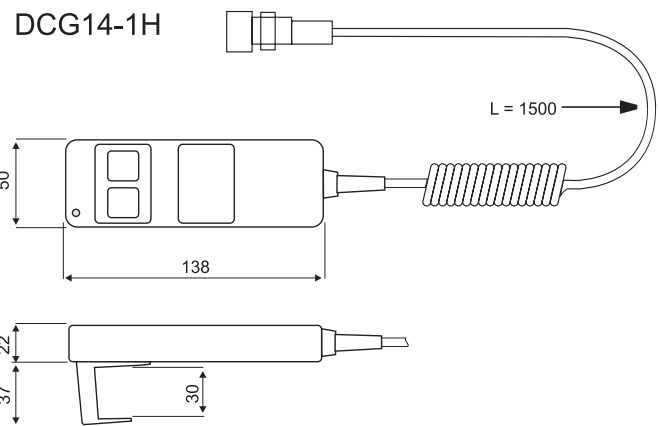
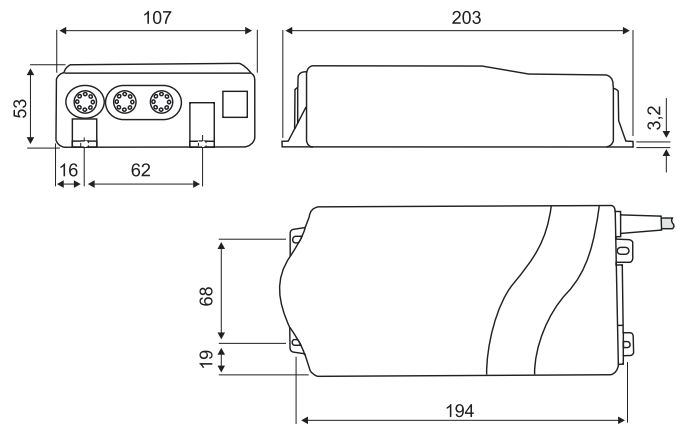

## DCG Actuator Controls, ordering key

Your Code	1	2	3	4	5
Example	<b>DCG</b>	<b>24</b>	<b>-1</b>	<b>M</b>	<b>-180</b>

### 1. Type of control

DCG = actuator control type DCG

### 2. Output voltage

24 = 24 Vdc

### 3. Type of operation

-1 = operation of a single actuator

-2 = operation of two parallel synchronous actuators

### 4. Input voltage

M = 230 Vac

U = 115 Vac

### 5. Matching actuator

-0150 = single drive of LA1, E050 and Q050

-0160 = single drive of all LM80 for vertical operation

-0170 = single drive of all LM80 for horizontal operation, E150 without limit switches

-0180 = single drive of TC16

-0190 = single drive of LA10, LA14, PPA-DC and Movoact-DC

-0260 = parallel synchronous drive of LM80 inline versions with encoder feedback

-0280 = parallel synchronous drive of TC16 with encoder feedback

# Presentation of AC Actuator Controls

The rugged and robust AC actuator controls are designed to operate under the hardest of conditions. There are two main variants of the AC actuator controls. The AC-063 and the AC-247 ELS. The AC-063 come in two basic types. One without limit switch inputs which is designed to work with actuators that have built in limit switches and one with limit switch inputs that is designed to work with actuators using external limit switches. The AC-247ELS has an electronic limit switch function which will halt the actuator at the end of its stroke or when it comes in contact with an obstacle.



## Limit switch inputs

Some controls have limit switch inputs that are used to stop the actuator and thus limiting the maximum forward and reverse stroke of the actuator. Limit switches, magnetic sensors, relay contacts or any other type of potential free contact can be connected to the limit switch inputs.

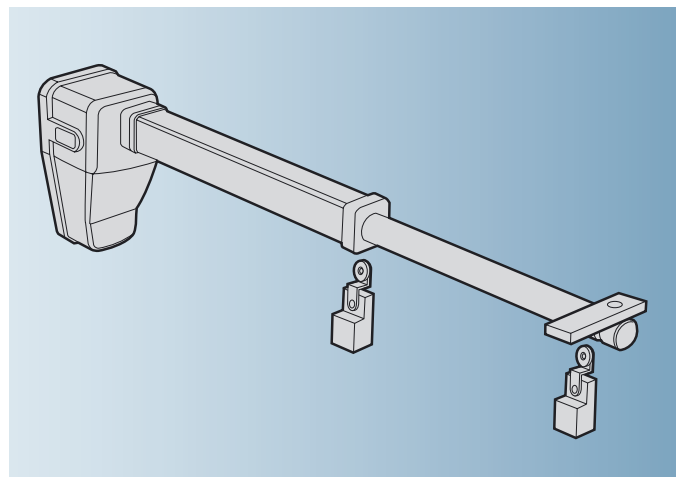

## Electronic limit switches

Controls that have electronic limit switches (ELS) have a built-in function that sense the current draw of the motor. When exceeding a factory set level the actuator stops moving in the direction in question while movement in the opposite direction remains possible. The electronic limit switches can be used to detect the ends of stroke of the actuator as well as detecting obstacles along the movement. However, do not use electronic limit switches as a safety function to avoid personal injuries as the power of the actuator can be very high before the motor is being de-energized.

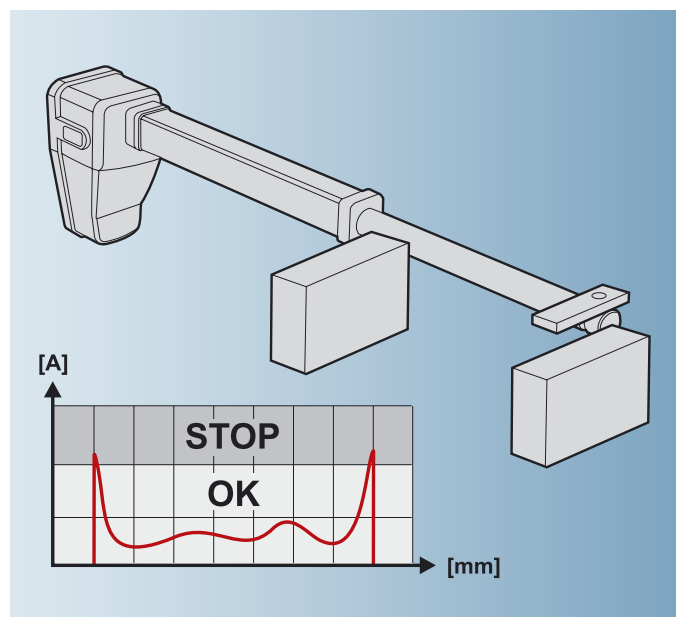

# Technical Data and Part Numbers for AC Actuator Controls

## Performance Specifications

Parameter	AC-063B	AC-063BC	AC-063B	AC-063BC	AC-063C	AC-063C	AC-247 ELS	AC-247 ELS	AC-247 ELS
Part number	DC24-1B	DC24-1BC	DCA24-1B	DCA24-1BC	DC24-1C	DCA24-1C	D604 110	D604 111	D604 112
Suitable actuators									
LA1	-	-	-	-	-	-	x	x	x
LA10	x	x	-	-	x	-	-	-	-
LA14	-	-	x	x	-	x	-	-	-
E050/Q050	-	-	-	-	-	-	x	x	x
E150	-	-	-	-	-	-	x	x	x
PPA-DC	x	x	-	-	x	-	-	-	-
Movoact-DC	x	x	-	-	x	-	-	-	-
LoadMaster 80	-	-	-	-	-	-	x	x	x
Supply voltage [V]									
Vdc	12 – 36	12 – 36	12 – 36	12 – 36	-	-	12 or 24	12	24
Vac @ 50 Hz	-	-	-	-	230	230	-	-	-
Output voltage [Vdc]	12 – 36	12 – 36	12 – 36	12 – 36	24	24	12 or 24	12	24
Output current, max. [A]									
@ 12 Vdc output	30	30	30	30	-	-	10	12	-
@ 24 Vdc output	17	17	17	17	17	17	5	-	8
@ 36 Vdc output	12	12	12	12	-	-	-	-	-
Max. duty cycle @ 25 °C [%]	10	10	10	10	10	10	10	10	10
Weight of control [kg]	3	3	3	3	3	0,3	0,3	0,3	0,3
Limit switch inputs	no	no	yes	yes	no	yes	no	no	no
Electronic limit switches	no	no	no	no	no	no	yes	yes	yes
Included hand control	no <sup>1</sup>	DCG14-1H	no <sup>1</sup>	DCG14-1H	DCG14-1H	DCG14-1H	DCG14-1H	DCG14-1H	DCG14-1H

<sup>1</sup> To these controls the customer can.

## Dimensions

### AC-063B/BC

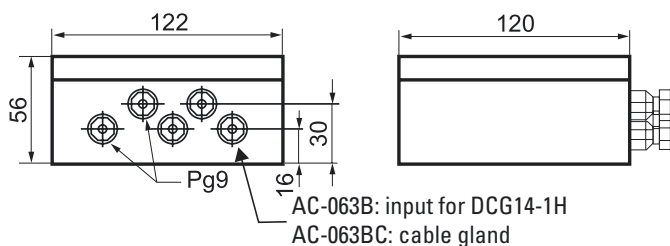

### AC-063C

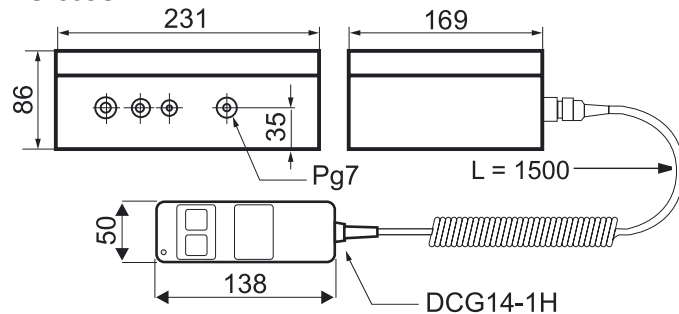

### AC-247 ELS

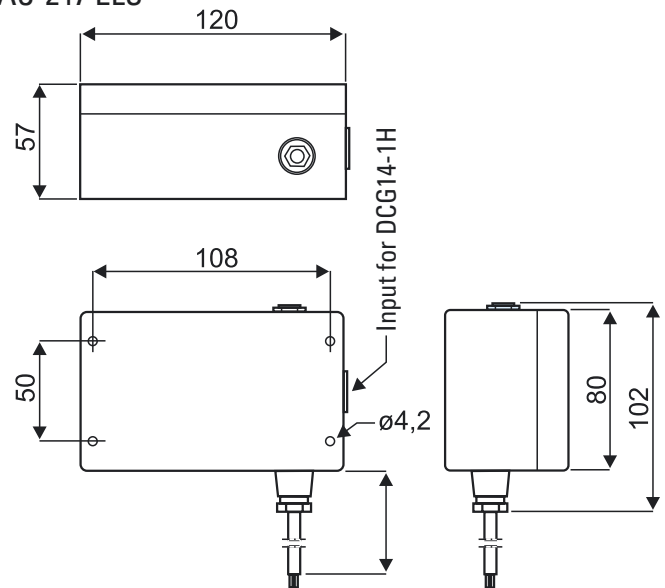

# Actuator Control Accessories

On the following pages you can find some electrical accessories to the actuators. The wiring of the components to the actuators and the controls are shown in the manuals of the products.

## DPDT Switch

The DPDT switch can be used to run all actuators with 12 Vdc, 24 Vdc, 36 Vdc, 1 × 115 Vac or 1 × 230 Vac supply voltages. When running an 1 × 115 Vac or an 1 × 230 Vac actuator a capacitor must be wired into the circuit.



## Performance Specifications

Parameter		DPDT switch
Max. voltage	[Vac]	270
Max. current	[A]	15
Part number		830-8004-016

## DPDT Switch Box

The DPDT switch box consists of an enclosure in which a DPDT switch is mounted. Connections to the box is made in the same way as for the above DPDT switch. There is no space in the box for any capacitor.



## Performance Specifications

Parameter		DPDT switch box
Max. voltage	[Vac]	270
Max. current	[A]	15
Part number		6932-101-054

# Actuator Control Accessories

## Magnetic Sensors

Magnetic sensors can be fitted in to the T-slot running along the profile on LA14 and LA24 actuators and can be used to all AC-063 controls that has limit switch inputs. The magnetic sensors come in normally open (NO) or normally closed (NC) versions. The sensor cable is molded in to the switch.



### Performance Specifications

Parameter	Magnetic sensors	
Max. power	[W]	10
Max. voltage	[Vdc]	43
Max. current	[A]	0,5
Max. contact resistance	[ohm]	0,2
Cable length	[mm]	3000
Cable lead cross section	[mm <sup>2</sup> ]	2 × 0,12
Protection degree	IP67	
Part numbers		
normally open	D535 070	
normally closed	D535 071	

## Limit Switches

The limit switches can be used to AC-063 controls that have limit switch inputs. The limit switches have cables of 1, 5 or 10 metres that are molded in to the switch.



### Performance Specifications

Parameter	Limit switches	
Max. voltage	[V]	240
Max. current	[A]	1,5
Protection degree	IP67	
Cable lead cross section	[mm <sup>2</sup> ]	5 × 0,75
Part numbers		
with 1 m cable	671 545 0281	
with 5 m cable	671 545 0290	
with 10 m cable	671 545 0299	

## Capacitor

It is necessary to use a capacitor to be able to run an actuator with 1 × 115 or 1 × 230 Vac supply voltage.

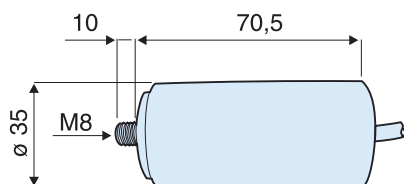

### Performance Specifications

Parameter	Capacitors		
Actuator supply voltage	[Vac]	115	230
Capacity	[µF]	35	10
Cable length	[mm]	170	170
Cable lead cross section	[mm <sup>2</sup> ]	2 × 0,75	2 × 0,75
Part number	D9200-448-002		D9200-448-003



\* DANAHER MOTION is a trademark.

Technical changes which improve the performance of the equipment may be made without prior notice! Printed in Germany.

© 2005 Danaher Motion EU200507-01 TJ

---

FOR IMMEDIATE ASSISTANCE:

Internet: [www.DanaherMotion.com](http://www.DanaherMotion.com)

United Kingdom: Danaher Motion  
Chartmoor Road, Chartwell Business Park  
Leighton Buzzard  
Bedfordshire, LU7 4WG  
Phone: +44 (0) 1525 243 243  
Fax: +44 (0) 1271 334502  
E-mail: [LMSEurope@danahermotion.com](mailto:LMSEurope@danahermotion.com)

France: Danaher Motion  
C.P 80018  
12, Rue Antoine Becquerel – Z.I. Sud  
F – 72026 Le Mans Cedex 2  
Phone: +33 (0) 243 50 03 30  
Fax: +33 (0) 243 50 03 39  
E-mail: [sales.france@tollo.com](mailto:sales.france@tollo.com)

Germany: Danaher Motion GmbH  
Wacholderstr. 40-42  
D-40489 Düsseldorf  
Phone: +49 (0) 203 9979-0  
Fax: +49 (0) 203 9979 155  
E-mail: [info@danahermotion.net](mailto:info@danahermotion.net)

Italy: Danaher Motion srl  
Via Brughetti  
I - 20030 Bovisio Masciago  
Phone: +39 (0) 362 594260  
Fax: +39 (0) 362 594263  
E-mail: [info@danahermotion.it](mailto:info@danahermotion.it)

Sweden: Danaher Motion  
Box 9053  
SE-29109 Kristianstad  
Phone: +46 (0)44 24 67 00  
Fax: +46 (0)44 24 40 85  
Email: [helpdesk@tollo.com](mailto:helpdesk@tollo.com)

Switzerland: Danaher Motion  
Rue Jardinière 157  
Case postale  
CH-2301 La Chaux-de-Fonds  
Phone: +41 (0) 32 925 61 11  
Fax: +41 (0) 32 925 65 96  
Email: [info@portescap.com](mailto:info@portescap.com)

---