



SQIO - SynqNet I/O Solutions

Hardware Specification



Helping you build a better machine, faster.

SQIO Hardware Specification



SynqNet™



Key Features

- SQIO Reference Design Kits bring SynqNet connectivity to existing customer designed I/O
- Standard SQIO modules provide flexible analog and digital I/O solutions tailored to machine requirements
- Place high-speed input capture points at any node on the network allowing more design flexibility
- I/O and motion performance data gathered together in real-time for in-depth system visibility and analysis
- Reduce system development time through tight integration between motion applications and I/O

Flexible SynqNet I/O Integration

The SQIO product family was designed with flexibility in mind for both SynqNet I/O solutions, as well as custom I/O device integration on a SynqNet network. SQIO is comprised of a SynqNet Interface Device with on-board connectors that accept standard digital and/or analog I/O boards. All the SQIO products connect together, so adding I/O capacity is as simple as plugging in additional SQIO boards. SQIO is also available as part of the SQIO Reference Design Kits, so custom add-on boards can be developed to be used with the SynqNet Interface Device ('SQID').

With the SQIO product line, a single network and the Motion Programming Interface (MPI: application programming interface) can now be utilized for both high performance complex motion control and I/O.

SQIO takes advantage of the 100 Mbit specification of SynqNet to achieve a new level of I/O performance. Error reporting and diagnostic data for SQIO is supported through the MPI, allowing error-recovery to be fully customized in the motion application. In addition, MotionConsole™ allows you to quickly scan, identify, and test all I/O associated with a XMP or ZMP-SynqNet type controller. And you can graph motion parameters against any I/O bit with MotionScope™, a powerful Windows® tool for motion analysis and real-time data graphing.

SynqNet Platform Overview

SynqNet is a digital machine control network specifically designed to meet the flexibility, performance, and safety requirements of today's demanding machine control applications. Built on the 100BT physical layer, SynqNet provides a synchronous real-time connection between motion controllers, servo drives, stepper drives, I/O modules, and custom devices.

Unique Features of SynqNet

- Network bandwidth for servo updates up to 48 kHz
- Support for up to 64 coordinated axes and 252 nodes. (MPI 3.05)
Support for up to 32 coordinated axes and 32 nodes. (MPI 3.04)
- Multi-vendor interoperable network
- Remote diagnostics over SynqNet
- Firmware and drive configuration download
- "Self-Healing" Fault tolerant operation using ring topology
- "HotReplace" allowing replacement of node without network shutdown



SynqNet Connectivity Diagram

SynqNet Drive and Motor



SynqNet Controller



SynqNet™

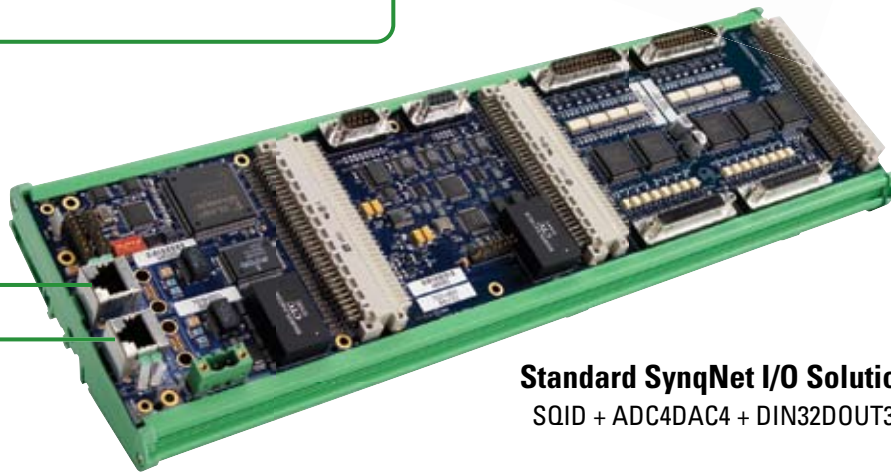

Standard SynqNet I/O Solution
SQID + ADC4DAC4 + DIN32DOUT32

Custom SynqNet I/O Solution
SQID + Custom I/O board

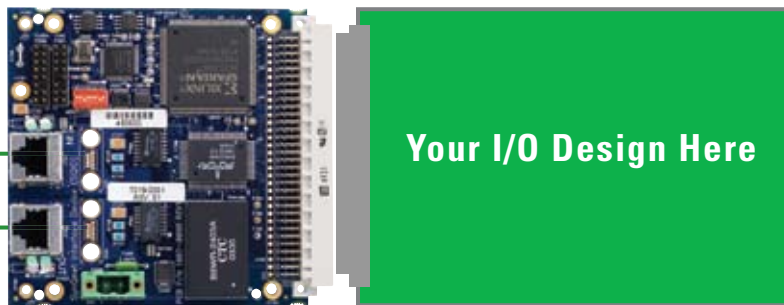

SQID

Your Cable

Use the 'SQID' to connect your own I/O to SynqNet.

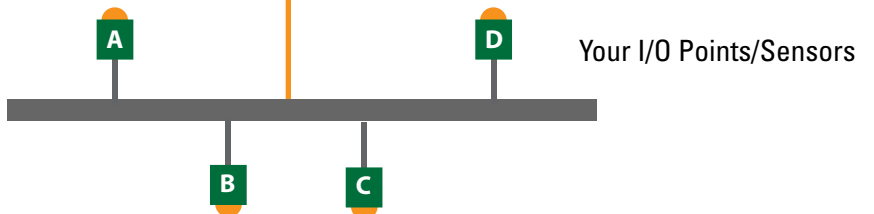

Overview of SQIO

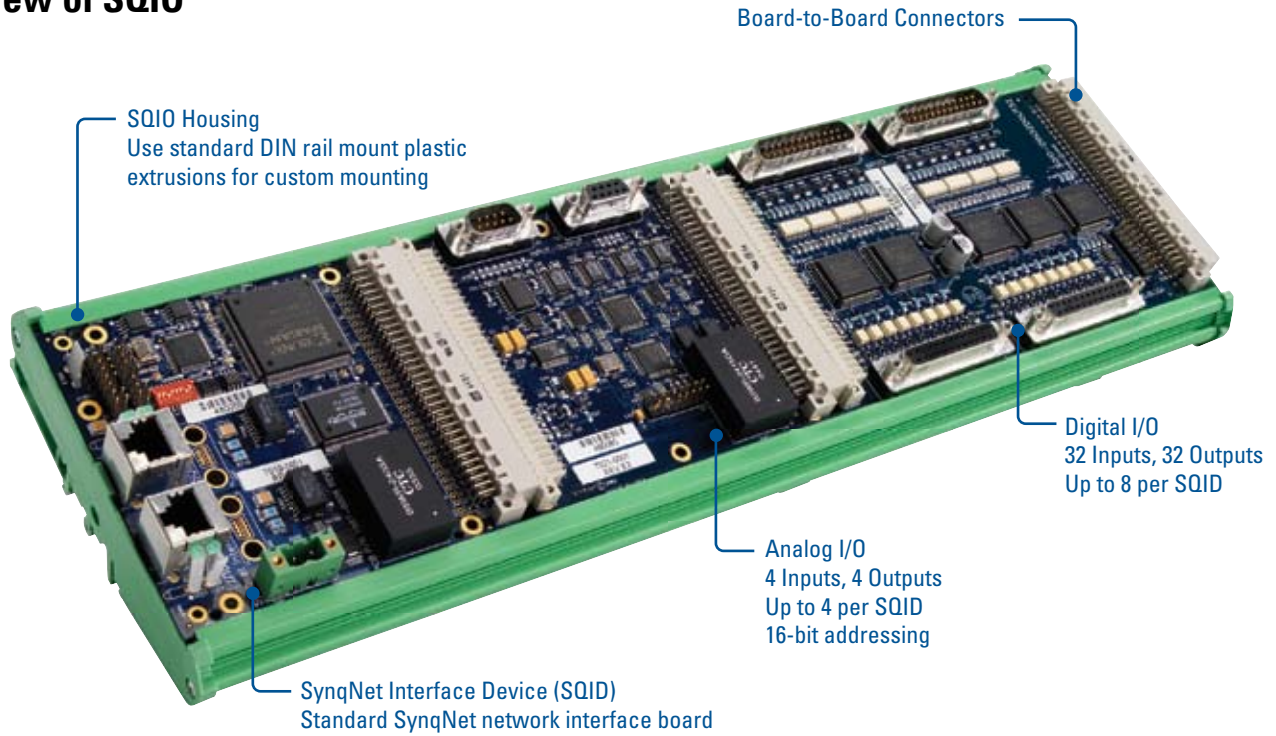

**SynqNet Interface Device
'SQID'**
T019-0001, T019-0002,
T019-0003, T019-0004

Provides SynqNet network interface & power to all other I/O boards. Use a 'SQID' and your own custom-built I/O board to interface your own system I/O with the SynqNet network.



**Digital I/O Device
'DIN32DOUT32'**
T020-0001

Provides 32 digital inputs and 32 digital opto-isolated outputs per board, (4) 25-pin 'D' digital I/O connectors, and board-to-board connectors for easy integration and future expansion. Up to 8 'DIN32DOUT32' boards per SQID.



**Analog I/O Device
'ADC4DAC4'**
T021-0001

Provides 4 analog inputs and 4 analog outputs per board, 16 bit addressing, (2) 9 'D' analog I/O connectors, and board-to-board connectors for easy integration and future expansion. Up to 4 boards per SQID.



**High Speed Capture Device
'HSIN32'**
T024-0001

Provides 32 digital inputs designed for high-speed capture (probe).



**Mixed Module
I/O Device
'MIXEDMODULE1'**
T022-0002

A combination of Digital and Analog I/O on one board.



**Digital I/O Breakout Board
'DIN32DOUT32-BO'**
8001-0042

Provides easy prototyping and wiring. Connects via the 'D' connectors on the 'DIN32DOUT32.' Convenient Phoenix Combicon vertical connectors.

Standard SQIO Implementations



SQID + HSIN32
10cm x 18.9cm



SQID + ADC4DAC4
10cm x 21.8cm



SQID + DIN32DOUT32
10cm x 27.5cm



SQID + MIXEDMODULE1
10cm x 40.5cm



SQID + DIN32DOUT32 + ADC4DAC4
10cm x 40.5cm

Assemble your own custom SQIO module by using a SQID interface board and any combination of SQIO I/O boards.

Here is a sample of common SQIO implementations.

NOTE: The HSIN board must be used with the appropriate SQID (T019-0004).

Custom SQIO Implementations

SQIO Reference Design Kits are also available for independent development of 'exact-fit' I/O solutions. Customize your own I/O modules and/or use a combination of existing SQIO I/O products to meet your I/O needs.

The SynqNet Reference Design Kits include:

- Reference schematics for various SynqNet nodes
- Reference Bill of Materials (BOM) w/approved vendors list
- SQID Module EEPROM specification
- SQIO Designers Manual
- Standard FPGA binary image (boot and run-time)
- Standard CPLD binary image
- Software API & Utilities for verification and debugging
- Full integration support

Example 1

Build a custom board for use with the SQID.

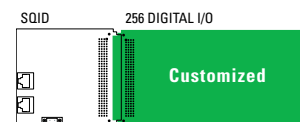

Example 2

Build a custom board for use with the SQID and another I/O board.

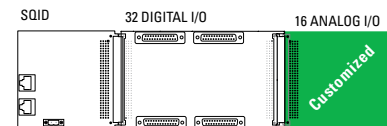

SynqNet Interface Device Board - 'SQID'

The SQID provides the necessary interface and power between I/O modules and the SynqNet network.



Specifications

Function	Parameter	Specification
Connectors	SynqNet Connectors	RJ-45 standard or Micro-D option
	SQID-to-Board Connectors	96-pin Type C
Environment	Operating Temperature	0-50° C
	Storage Temperature	0-50° C
	Humidity	20-80% RH, non-condensing
Power	Input	24 Vdc
	Current Consumption	100mA @ 3.3V
		300mA @ 1.8V

SQIO-SQID
 PN: T019-0001, T019-0002,
 T019-0003, T019-0004

Dimensions

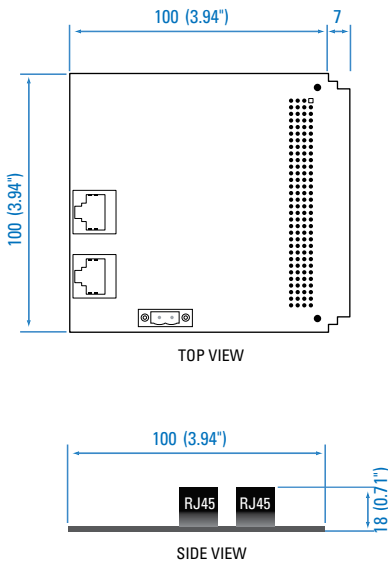

Pinouts and Connector Information

Power Connector
 Phoenix Connectors
 Mfg P/N 17 77 07 3

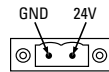

Mating Connector
 Phoenix Connectors
 Mfg P/N 17 77 98 9

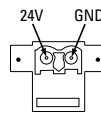

SynqNet Connector
 Standard RJ45

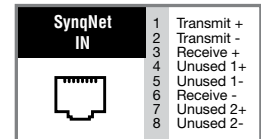

Mating Connector
 Shielded RJ45
 Recommended

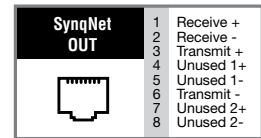

(Optional)
 Micro-D Connector
 Molex Inc.
 Mfg P/N 83611-9006

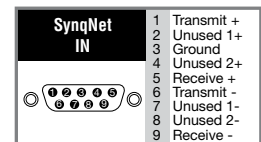

Micro-D Mating Connector
 Molex Inc.
 Mfg P/N 83421-9014

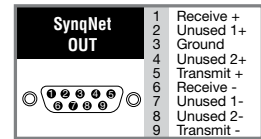

Part Number Table

Part Number	Description	SynqNet Connector
T019-0001	SQIO-SQID-RAFT-RJ-VERT	RJ45 vertical orientation
T019-0002	SQIO-SQID-RAFT-RJ-RA	RJ45 right angle orientation
T019-0003	SQIO-SQID-RAFT-UD-VERT	Micro D9, vertical orientation
T019-0004*	SQIO-SQID-RAFT-RJ-VERT-300	RJ45, vertical orientation

* The 'HSIN' must be used with the T019-0004.

High Speed Capture (Probe) Support

SQID + High Speed Digital Input Board (HSIN32) – 32 digital inputs designed for high-speed capture

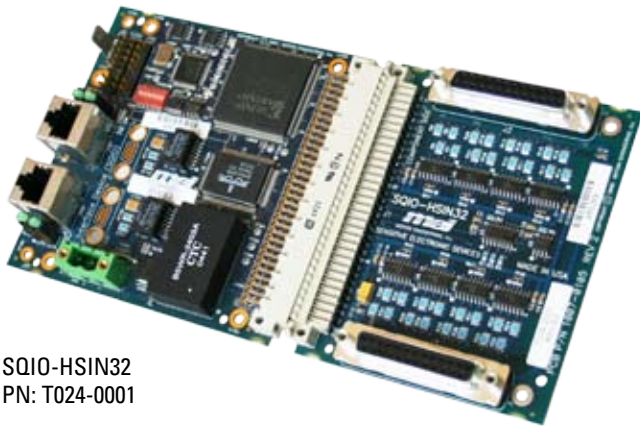

SQIO-HSIN32
PN: T024-0001

Specifications

Function	Parameter	Specification
Connectors	Digital Input Connectors	25-pin 'D' - (2F)
	Board-to-Board Connectors	96-pin Type R & Type C
Motor I/O	Motor Resources	2
	Digital Inputs	32 opto-isolated
	High-speed Capture Registers	16 (8/motor)
	Capture Latency	< 1 microsecond
Environment	Operating Temperature	0-50° C
	Storage Temperature	0-50° C
	Humidity	20-80% RH, non-condensing

Use up to 16 simultaneous high-speed capture inputs—the perfect solution for multiple position captures for on-the-fly adjustments.

*The HSIN32 must be connected to the (T019-0004) 'SQID' and cannot be attached onto another SQIO I/O board.

Dimensions

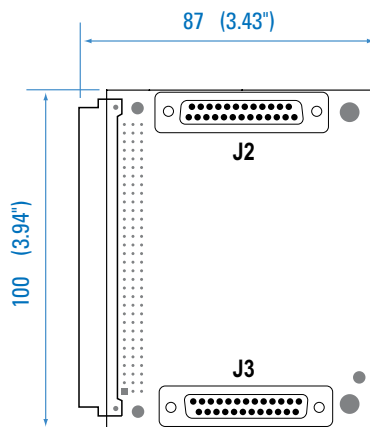

Pinouts and Connector Information

Digital I/O Connectors
Standard 25-pin 'D'
Connectors

Digital In 0		Digital In 1		
J2 	1	OPTO_IN0_0	14	OPTO_IN0_11
	2	OPTO_IN0_1	15	OPTO_IN0_12
	3	OPTO_IN0_2	16	OPTO_IN0_13
	4	OPTO_IN0_3	17	OPTO_IN0_14
	5	OPTO_IN0_4	18	OPTO_IN0_15
	6	OPTO_IN0_5	19	+24V (output)
	7	OPTO_IN0_6	20	24V_RTN
	8	OPTO_IN0_7	21	NC
	9	+24V (output)	22	NC
	10	24V_RTN	23	NC
	11	OPTO_IN0_8	24	NC
	12	OPTO_IN0_9	25	NC
	13	OPTO_IN0_10		
J3 	1	OPTO_IN1_0	14	OPTO_IN1_11
	2	OPTO_IN1_1	15	OPTO_IN1_12
	3	OPTO_IN1_2	16	OPTO_IN1_13
	4	OPTO_IN1_3	17	OPTO_IN1_14
	5	OPTO_IN1_4	18	OPTO_IN1_15
	6	OPTO_IN1_5	19	+24V (output)
	7	OPTO_IN1_6	20	24V_RTN
	8	OPTO_IN1_7	21	NC
	9	+24V (output)	22	NC
	10	24V_RTN	23	NC
	11	OPTO_IN1_8	24	NC
	12	OPTO_IN1_9	25	NC
	13	OPTO_IN1_10		

Digital Input Internal Circuit Diagram

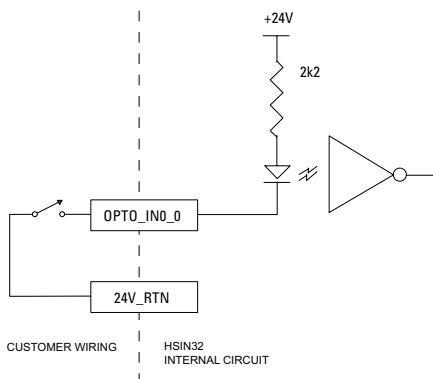

Sample Setup

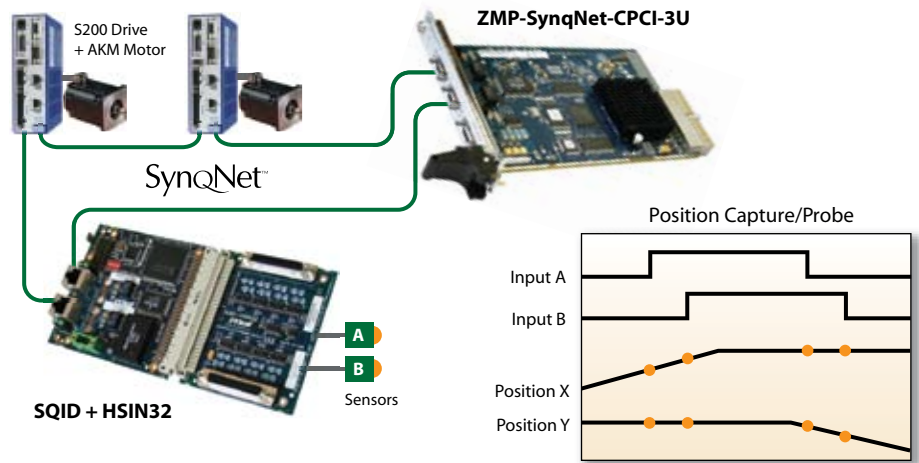

Each input event can capture positions of multiple axes.

Digital I/O Board - 'DIN32DOUT32'

The Digital I/O board contains 32 digital inputs and 32 digital outputs.

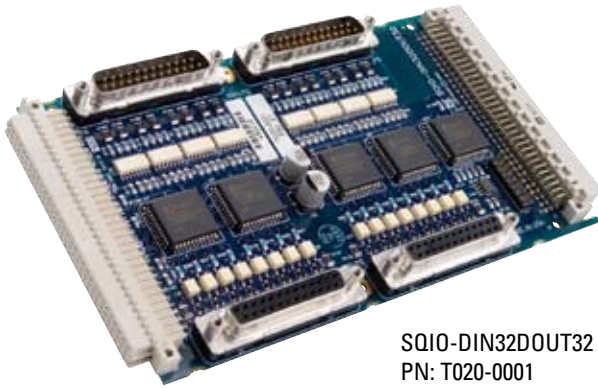

SQIO-DIN32DOUT32
PN: T020-0001

Specifications

Function	Parameter	Specification
Connectors	Digital I/O Connectors	6.35mm 25-pin 'D' - (2M & 2F)
	Board-to-Board Connectors	96-pin Type R & Type C
Digital I/O	Digital Inputs	32 opto-isolated
	Digital Outputs	32 opto-isolated
	Voltage	5-24 Vdc
	Total Current Consumption	Max 200mA @ 3.3V
Environment	Operating Temperature	0-50° C
	Storage Temperature	0-50° C
	Humidity	20-80% RH, non-condensing
Power	Total Current Consumption	Max 300mA @ 3.3V Max 70mA @ 24V

Dimensions

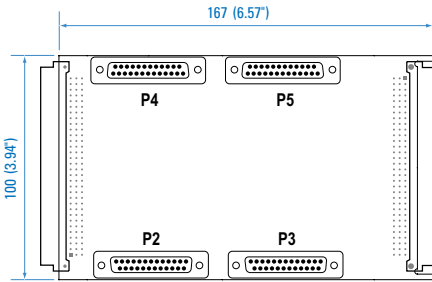

Breakout Connector Board

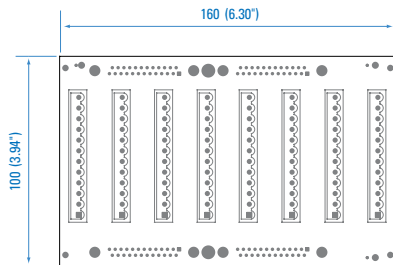

Pinouts and Connector Information

Digital I/O Connectors
Standard 25-pin 'D' Connectors

Connector	Pin	Signal	Connector	Pin	Signal
P4 (Digital In 0-1)	1	B0 DIN 0	P5 (Digital In 2-3)	1	B2 DIN 0
	2	B0 DIN 2		2	B2 DIN 2
	3	B0 DIN 4		3	B2 DIN 4
	4	B0 DIN 6		4	B2 DIN 6
	5	NC		5	NC
	6	B0 COM		6	B2 COM
	7	NC		7	NC
	8	B1 DIN 1		8	B3 DIN 1
	9	B1 DIN 3		9	B3 DIN 3
	10	B1 DIN 5		10	B3 DIN 5
	11	B1 DIN 7		11	B3 DIN 7
	12	NC		12	NC
	13	B1 COM		13	B3 COM
P2 (Digital Out 0-1)	1	B0 DOUT 0	P3 (Digital Out 2-3)	1	B2 DOUT 0
	2	B0 DOUT 2		2	B2 DOUT 2
	3	B0 DOUT 4		3	B2 DOUT 4
	4	B0 DOUT 6		4	B2 DOUT 6
	5	B0 +24V		5	B2 +24V
	6	B0 24V RTN		6	B2 24V RTN
	7	NC		7	NC
	8	B1 DOUT 1		8	B3 DOUT 1
	9	B1 DOUT 3		9	B3 DOUT 3
	10	B1 DOUT 5		10	B3 DOUT 5
	11	B1 DOUT 7		11	B3 DOUT 7
	12	B1 +24V		12	B3 +24V
	13	B1 24V RTN		13	B3 24V RTN

Digital I/O Internal Circuit Diagrams

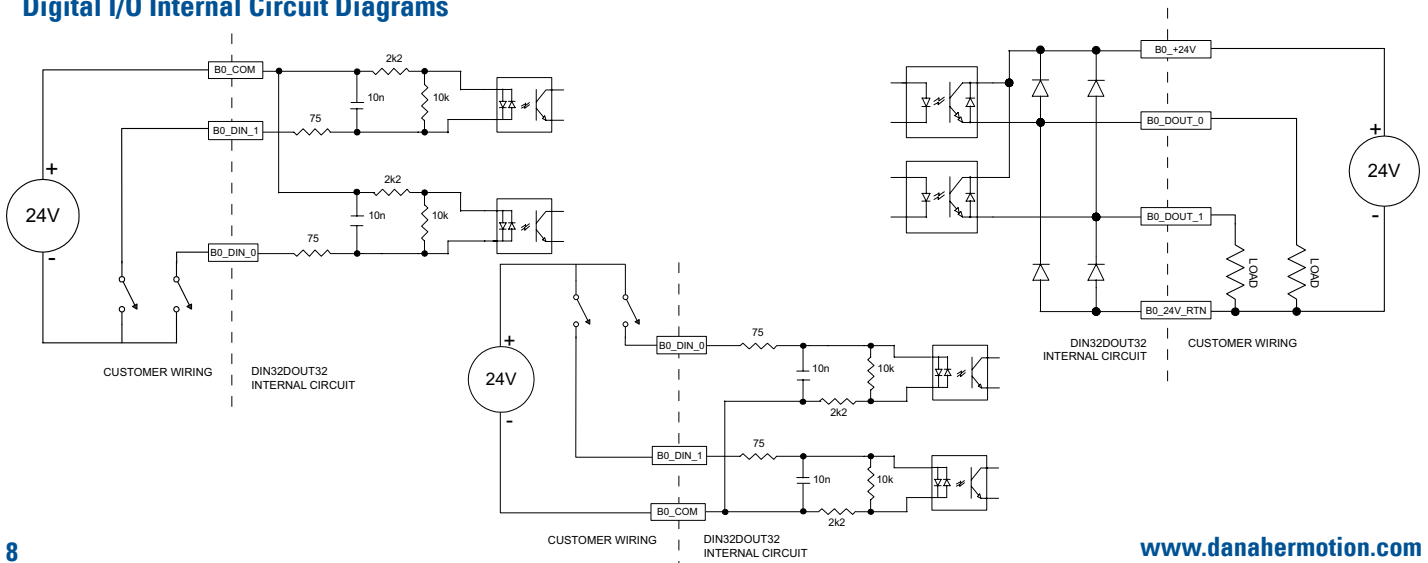

Analog I/O Board - 'ADC4DAC4'

The Analog I/O board contains 4 ADC and 4 DAC.



SQ10-ADC4DAC4
PN: T021-0001

Specifications

Function	Parameter	Specification
Connectors	Analog I/O Connectors	9-pin 'D' - (1M & 1F)
	Board-to-Board Connectors	96-pin Type R & Type C
Analog I/O	Analog Inputs	4
	Analog Outputs	4
	Addressing	16-bit addressing
	Input Voltage & Output Voltage	±10V, fully differentiated
	Slew & Settling Time	11µS
Environment	Total Current Consumption	106mA @ ± 15V
	Operating Temperature	0-50° C
	Storage Temperature	0-50° C
Power	Humidity	20-80% RH, non-condensing
	Total Current Consumption	Max 120mA @ 3.3V Max 120mA @ 24V

Dimensions

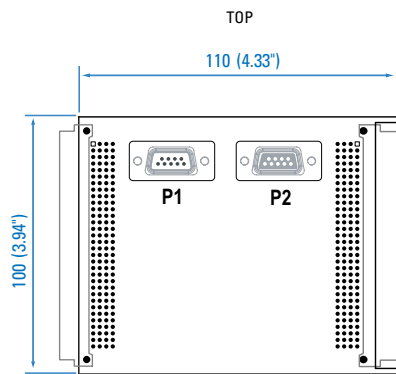

Pinouts and Connector Information

Analog I/O Connectors
Standard 9-pin
'D' Connectors

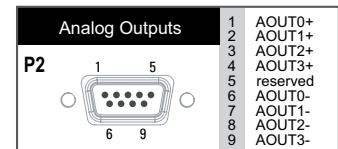
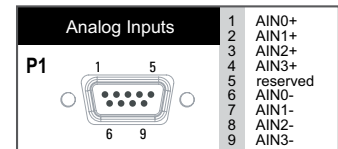

Analog I/O Internal Circuit Diagrams

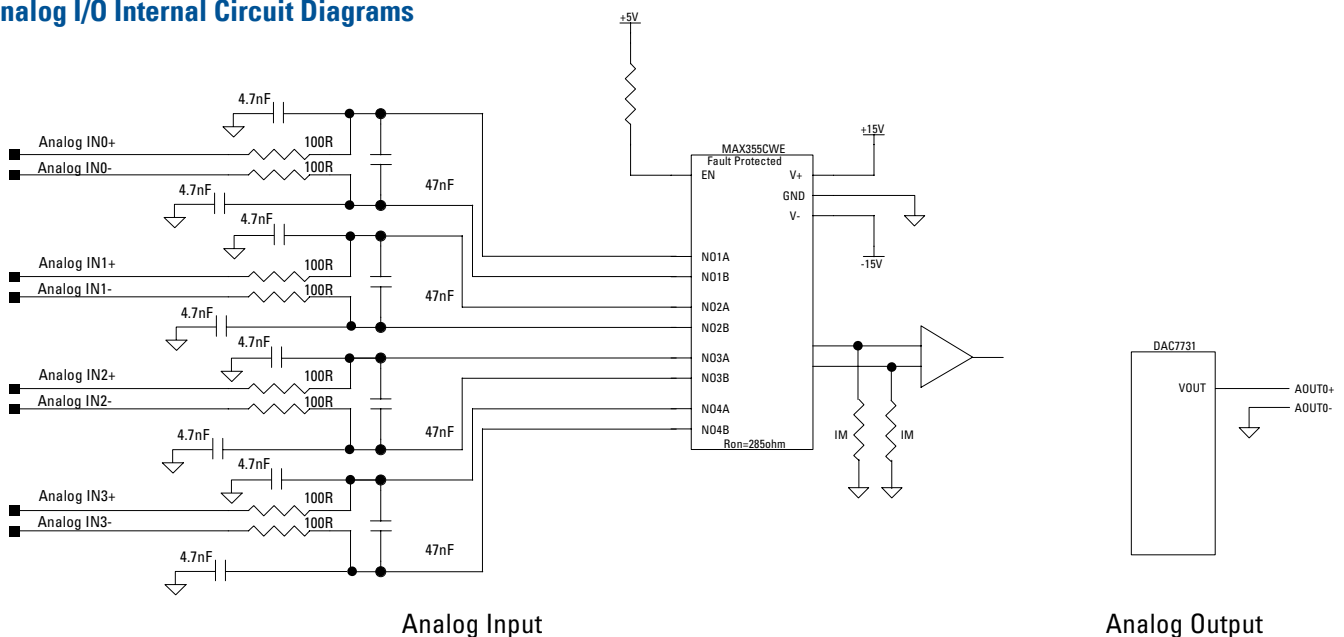

Mixed Module I/O Board - 'MIXEDMODULE1'

The Mixed Module I/O board contains 64 digital inputs, 64 digital outputs, 16 ADC, and 8 DAC.

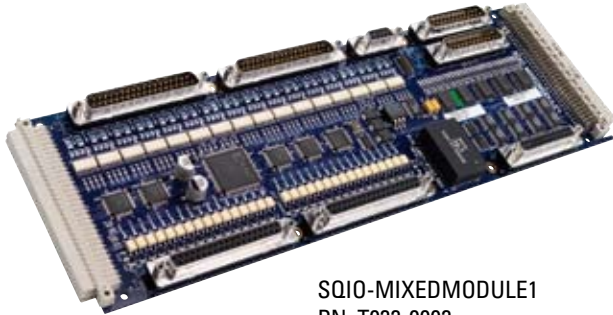

SQIO-MIXEDMODULE1
PN: T022-0002

NOTE: The wiring diagrams for the MixedModule1 are the same as the Digital I/O and Analog I/O boards.

Specifications

Function	Parameter	Specification
Connectors	Analog I/O Connectors	9-pin 'D' - (1M & 1F)
	Board-to-Board Connectors	96-pin Type R & Type C
Digital I/O	Digital Inputs	64 opto-isolated
	Digital Outputs	64 opto-isolated, current sourcing
	Max. Input Voltage	28.8 Vdc
	Total Current Consumption	Max 200mA @ 3.3V
Analog I/O	Analog Inputs	16, differential
	Analog Outputs	8, single ended
	Addressing	16-bit addressing
	Input Voltage & Output Voltage	±10V, fully differentiated
	Slew & Settling Time	11µS
	Total Current Consumption	106mA @ ± 15V
Environment	Operating Temperature	0-50° C
	Storage Temperature	0-50° C
	Humidity	20-80% RH, non-condensing
Power	Total Current Consumption	Max 650mA @ 3.3V Max 200mA @ 24V

Dimensions

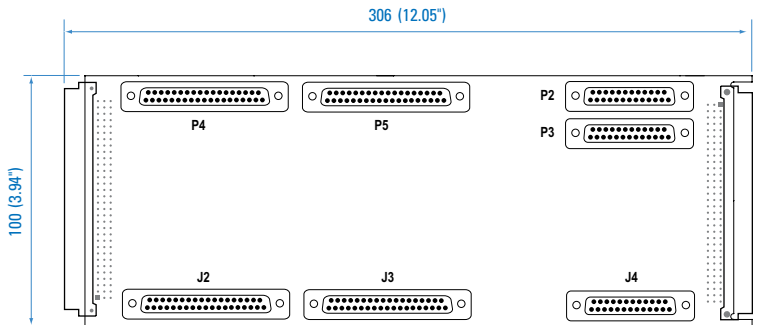

Pinouts and Connector Information

Analog I/O Connectors Standard 25-pin 'D' Connectors

Analog In 0-7		Analog In 8-15	
1 AIN0+	14 AIN0-	1 AIN8+	14 AIN8-
2 ANALOG_GND_2	15 AIN1+	2 ANALOG_GND_2	15 AIN9+
3 AIN1-	16 ANALOG_GND_2	3 AIN9-	16 ANALOG_GND_2
4 AIN2+	17 AIN2-	4 AIN10+	17 AIN10-
5 ANALOG_GND_2	18 AIN3+	5 ANALOG_GND_2	18 AIN11+
6 AIN3-	19 ANALOG_GND_2	6 AIN11-	19 ANALOG_GND_2
7 AIN4+	20 AIN4-	7 AIN12+	20 AIN12-
8 ANALOG_GND_2	21 AIN5+	8 ANALOG_GND_2	21 AIN13+
9 AIN5-	22 ANALOG_GND_2	9 AIN13-	22 ANALOG_GND_2
10 AIN6+	23 AIN6-	10 AIN14+	23 AIN14-
11 ANALOG_GND_2	24 AIN7+	11 ANALOG_GND_2	24 AIN15+
12 AIN7-	25 ANALOG_GND_2	12 AIN15-	25 ANALOG_GND_2
13 ANALOG_GND_2		13 ANALOG_GND_2	

Analog In 0-7		Analog Out 0-7	
1 AOUT0+	14 AOUT0-	1 AOUT0+	14 AOUT0-
2 ANALOG_GND_1	15 AOUT1+	2 ANALOG_GND_1	15 AOUT1+
3 AOUT1-	16 ANALOG_GND_1	3 AOUT1-	16 ANALOG_GND_1
4 AOUT2+	17 AOUT2-	4 AOUT2+	17 AOUT2-
5 ANALOG_GND_1	18 AOUT3+	5 ANALOG_GND_1	18 AOUT3+
6 AOUT3-	19 ANALOG_GND_1	6 AOUT3-	19 ANALOG_GND_1
7 AOUT4+	20 AOUT4-	7 AOUT4+	20 AOUT4-
8 ANALOG_GND_1	21 AOUT5+	8 ANALOG_GND_1	21 AOUT5+
9 AOUT5-	22 ANALOG_GND_1	9 AOUT5-	22 ANALOG_GND_1
10 AOUT6+	23 AOUT6-	10 AOUT6+	23 AOUT6-
11 ANALOG_GND_1	24 AOUT7+	11 ANALOG_GND_1	24 AOUT7+
12 AOUT7-	25 ANALOG_GND_1	12 AOUT7-	25 ANALOG_GND_1
13 ANALOG_GND_1		13 ANALOG_GND_1	

Digital I/O Connectors

Standard 37-pin 'D' Connectors

Digital In 0-31		Digital Out 0-31	
1 B2_DIN_0	20 B2_DIN_1	1 B2_DOUT_0	20 B2_DOUT_1
2 B2_DIN_2	21 B2_DIN_3	2 B2_DOUT_2	21 B2_DOUT_2
3 B2_DIN_4	22 B2_DIN_5	3 B2_DOUT_4	22 B2_DOUT_5
4 B2_DIN_6	23 B2_DIN_7	4 B2_DOUT_6	23 B2_DOUT_7
5 B3_DIN_0	24 B3_DIN_1	5 B3_DOUT_0	24 B3_DOUT_1
6 B3_DIN_2	25 B3_DIN_3	6 B3_DOUT_2	25 B3_DOUT_3
7 B3_DIN_4	26 B3_DIN_5	7 B3_DOUT_4	26 B3_DOUT_5
8 B3_DIN_6	27 B3_DIN_7	8 B3_DOUT_6	27 B3_DOUT_7
9 NC	28 NC	9 B0123_24V	28 B0123_24V
10 B0123_COM	29 B0123_COM	10 B0123_24V_RTN	29 B0123_24V_RTN
11 NC	30 B0_DIN_0	11 NC	30 B0_DOUT_0
12 B0_DIN_1	31 B0_DIN_2	12 B0_DOUT_1	31 B0_DOUT_2
13 B0_DIN_3	32 B0_DIN_4	13 B0_DOUT_3	32 B0_DOUT_4
14 B0_DIN_5	33 B0_DIN_6	14 B0_DOUT_5	33 B0_DOUT_6
15 B0_DIN_7	34 B1_DIN_0	15 B0_DOUT_7	34 B1_DOUT_0
16 B1_DIN_1	35 B1_DIN_2	16 B1_DOUT_1	35 B1_DOUT_2
17 B1_DIN_3	36 B1_DIN_4	17 B1_DOUT_3	36 B1_DOUT_4
18 B1_DIN_5	37 B1_DIN_6	18 B1_DOUT_5	37 B1_DOUT_6
19 B1_DIN_7		19 B1_DOUT_7	

Digital In 32-64		Digital Out 32-64	
1 B6_DIN_0	20 B6_DIN_1	1 B6_DOUT_0	20 B6_DOUT_1
2 B6_DIN_2	21 B6_DIN_3	2 B6_DOUT_2	21 B6_DOUT_3
3 B6_DIN_4	22 B6_DIN_5	3 B6_DOUT_4	22 B6_DOUT_5
4 B6_DIN_6	23 B6_DIN_7	4 B6_DOUT_6	23 B6_DOUT_7
5 B7_DIN_0	24 B7_DIN_1	5 B7_DOUT_0	24 B7_DOUT_1
6 B7_DIN_2	25 B7_DIN_3	6 B7_DOUT_2	25 B7_DOUT_3
7 B7_DIN_4	26 B7_DIN_5	7 B7_DOUT_4	26 B7_DOUT_5
8 B7_DIN_6	27 B7_DIN_7	8 B7_DOUT_6	27 B7_DOUT_7
9 NC	28 NC	9 B4567_24V	28 B4567_24V
10 B4567_COM	29 B4567_COM	10 B4567_24V_RTN	29 B4567_24V_RTN
11 NC	30 B4_DIN_0	11 NC	30 B4_DOUT_0
12 B4_DIN_1	31 B4_DIN_2	12 B4_DOUT_1	31 B4_DOUT_2
13 B4_DIN_3	32 B4_DIN_4	13 B4_DOUT_3	32 B4_DOUT_4
14 B4_DIN_5	33 B4_DIN_6	14 B4_DOUT_5	33 B4_DOUT_6
15 B4_DIN_7	34 B5_DIN_0	15 B4_DOUT_7	34 B5_DOUT_0
16 B5_DIN_1	35 B5_DIN_2	16 B5_DOUT_1	35 B5_DOUT_2
17 B5_DIN_3	36 B5_DIN_4	17 B5_DOUT_3	36 B5_DOUT_4
18 B5_DIN_5	37 B5_DIN_6	18 B5_DOUT_5	37 B5_DOUT_6
19 B5_DIN_7		19 B5_DOUT_7	

Mounting Information

Mounting Information

SQIO modules utilize standard Phoenix Contact DIN rail mount plastic extrusions.
www.phoenixcon.com

Plastic Extrusion:
29 52 02 0 / UM100 / Custom Length

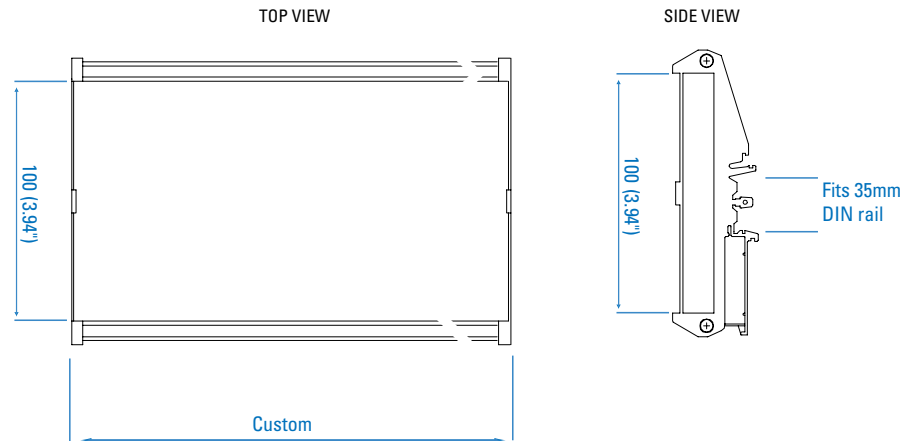

Pre-cut SQIO Housing

Part Number	SQIO Setup	Description
1016-0300	SQID + DIN32DOUT32	Housing, Kit, SQIO, 27.15cm
1016-0301	SQID + ADC4DAC4	Housing, Kit, SQIO, 21.45cm
1016-0302	SQID + MIXEDMODULE1	Housing, Kit, SQIO, 40.35cm
1016-0303	SQID + DIN32DOUT32 + ADC4DAC4	Housing, Kit, SQIO, 38.25cm
1016-0304	SQID + ADC4DAC4 + ADC4DAC4	Housing, Kit, SQIO, 32.55cm
1016-0305	SQID + DIN32DOUT32 + DIN32DOUT32	Housing, Kit, SQIO, 43.95cm
1016-0306	SQID + HSIN32	Housing, Kit, SQIO, 18.45cm

Accessories



Digital I/O Breakout Board
'DIN32DOUT32-BO'
8001-0042

Used with the 'DIN32DOUT32' board for easy prototyping and wiring.
Connects via the 'D' connectors.
Convenient Phoenix Combicon vertical connectors.

Additional SQIO products are also available upon request.

- **Board Protective Covers**
Protects I/O electrical circuits from direct exposure.
- **Optional DIN Rail Mounting**
Customizable extruded mounting material that conforms to any configuration.

USA, Canada and Mexico

Danaher Motion
203A West Rock Road
Radford, VA 24141 USA
Phone: 1-540-633-3400
Fax: 1-540-639-4162
E-mail: DMAC@danahermotion.com

United Kingdom

Danaher Motion
Chartmoor Road, Chartwell Business Park
Leighton Buzzard, Bedfordshire
LU7 4WG; United Kingdom
Phone: +44 (0)1525 243 243
Fax: +44 (0)1525 243 244
E-mail: sales.uk@danahermotion.com

Germany

Danaher Motion GmbH
Sales Office North
Wacholderstr. 40-42
40489 Düsseldorf
Germany
Phone: +49 (0) 203 9979 214
Fax: +49 (0) 203 9979 3214
E-Mail: iris.tolusch@danahermotion.com

Danaher Motion GmbH

Sales Office South West
Brückenfeldstraße 26/1
75015 Bretten
Germany
Phone: +49 (0) 7252 97390 56
Fax: +49 (0) 7252 97390 55
E-Mail: kerstin.mueller@danahermotion.com

Danaher Motion GmbH

Sales Office North
Sales Office South East
Kiesgräble 7
89129 Langenau
Germany
Phone: +49 (0) 7471 62 23 23
Fax: +49 (0) 7471 62 23 26
E-Mail: ursula.koschak@danahermotion.com

France

Danaher Motion
C.P 80018
12, Rue Antoine Becquerel – Z.I. Sud
72026 Le Mans Cedex 2
France
Phone: +33 (0) 243 50 03 20
Fax: +33 (0) 243 50 03 39
E-mail: sales.france@danahermotion.com

Italy

Danaher Motion srl
Largo Brughetti
20030 Bovisio Masciago
Italy
Phone: +39 0362 594260
Fax: +39 0362 594263
E-mail: info@danahermotion.it

Sweden

Danaher Motion
Box 9053
291 09 Kristianstad
Sweden
Phone: +46 (0) 44-24 67 00
Fax: +46 (0) 44-24 40 85
E-mail: sales.scandinavia@danahermotion.com

Switzerland

Danaher Motion SA
La Pierreire 2
1029 Villars-Ste-Croix
Switzerland
Phone: +41 (0) 21 631 33 33
Fax: +41 (0) 21 636 05 09
E-mail: info@danaher-motion.ch

China

Danaher Motion
Rm 2205, Scitech Tower
22 Jianguomen Wai Street
Beijing, China, 100004
Phone: +86 10 6515 0260
Fax: +86 10 6515 0263
E-mail: chinainfo@danahermotion.com.cn

Japan

Danaher Motion Japan
2F, Tokyu Reit Hatchobori Bldg,
2-7-1 Hatchobori Chuo-ku,
Tokyo 104-0032 Japan
Phone: +81-3-6222-1051
Fax: +81-3-6222-1055
E-mail: info@danahermotion.co.jp

Asia Pacific

Danaher Motion (HK) Ltd
Unit A, 16 Floor, 169 Electric Road
Manulife Tower, North Point
Hong Kong
Phone: +852 2503 6581
Fax: +852 2571 8585
E-mail: victor.lim@danahermotion.com

www.danahermotion.com



Helping you build a better machine, faster.